



# Modulus Flip Table

Product Data Specification

# Modulus Flip Table

## Product Data Specification

Modulus flip table frames are the industry leaders. Strong, AFRDI certified and flexible. The polished foot is excellent for training spaces that have dirty workwear - meaning a hardy, easy clean finish in all the right places.

### Standard Features

- 5 minutes assembly time
- Very durable, one handed flip mechanism, simply pull and tilt with safety stay upright locks
- Perfect for boardroom, training, conference, classroom and cafeteria tables
- AFRDI approved for severe commercial use
- Frames finished in Gloss White or Matt Black powdercoat
- 25 mm worksurfaces finished in White melamine on E0 grade substrate with matching PVC edge
- Fixed height 720 mm (incl worksurface)
- Use multiple tables to create more worksurface space or nest tables away when not in use
- 70 mm castors make for easy moving - 2 locking castors to set in place
- Each table includes 2 sets of flip table links

### Standard Available Sizes

1200w x 600d mm  
1200w x 750d mm  
1500w x 600d mm  
1500w x 750d mm  
1800w x 600d mm  
1800w x 750d mm  
1800w x 900d mm

### Frame Sizes

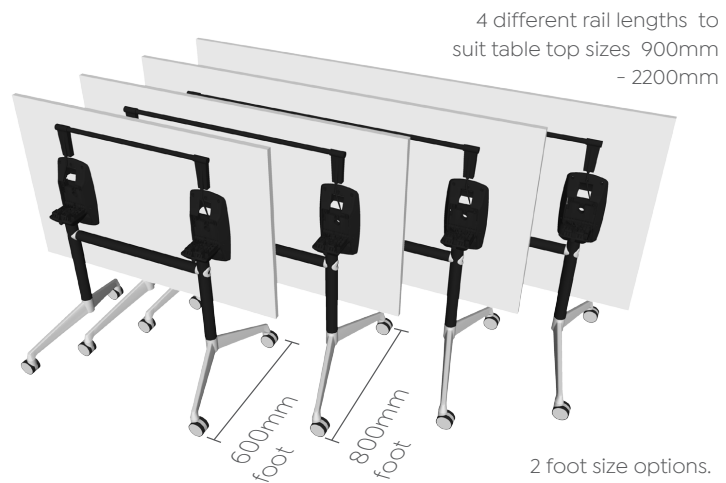

Live chat to the team @ [myolg.online](https://myolg.online)