

LX8000 EDGE FRAME

ARCHITECTURAL PORCELAIN WRITING SURFACE

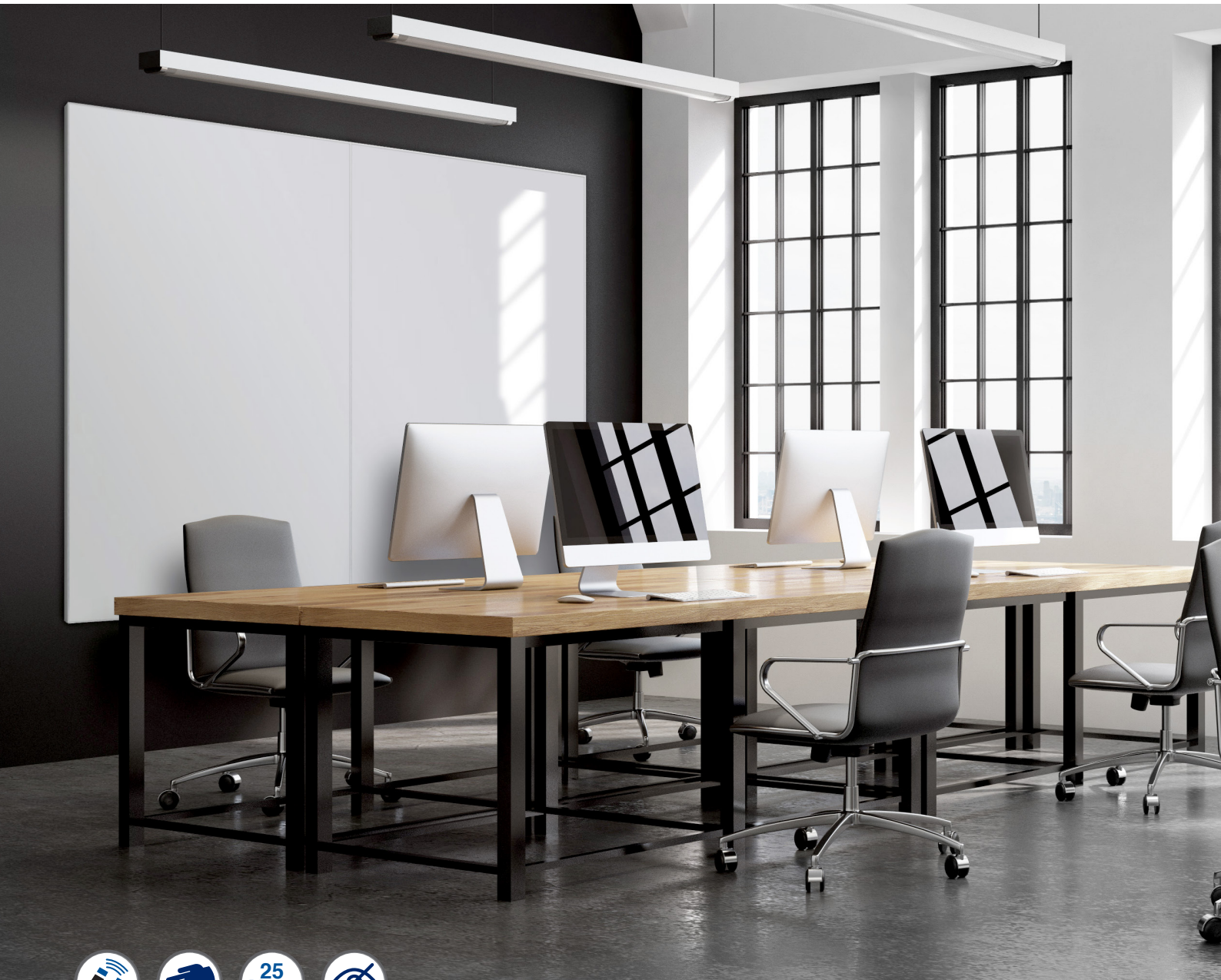

Excellent hardwearing porcelain magnetic surface for general use applications. Use with drywipe pens and any magnetic accessory. Surface guaranteed for 25 years.

Designed to be installed with no visible fixings, our low profile 4mm edge boards can be butt joined horizontally or vertically, side by side to create a vast communication wall.

LX8000 EDGE FRAME

ARCHITECTURAL WRITING SURFACE

12 standard sizes stocked, however panels can be any size up to 3000 x 1200mm

20mm frame with 4mm lip sits against the wall with invisible fixings making the board appear seamless and integrated into any space.

Whiteboard panels can be mixed and matched with any pinboard or Echopanel required also using the EDGE LX8000 minimalist frame to fully integrate with your office décor or provide acoustic benefits to your environment.



Code	Description	Size (mm)
LX8-9060	EDGE LX8000 Architectural Writing Surface	900 x 600
LX8-9090	EDGE LX8000 Architectural Writing Surface	900 x 900
LX8-1290	EDGE LX8000 Architectural Writing Surface	1200 x 900
LX8-1212	EDGE LX8000 Architectural Writing Surface	1200 x 1200
LX8-1590	EDGE LX8000 Architectural Writing Surface	1500 x 900
LX8-1512	EDGE LX8000 Architectural Writing Surface	1500 x 1200
LX8-1890	EDGE LX8000 Architectural Writing Surface	1800 x 900
LX8-1812	EDGE LX8000 Architectural Writing Surface	1800 x 1200
LX8-2012	EDGE LX8000 Architectural Writing Surface	2000 x 1200
LX8-2112	EDGE LX8000 Architectural Writing Surface	2100 x 1200
LX8-2412	EDGE LX8000 Architectural Writing Surface	2400 x 1200
LX8-3012	EDGE LX8000 Architectural Writing Surface	3000 x 1200

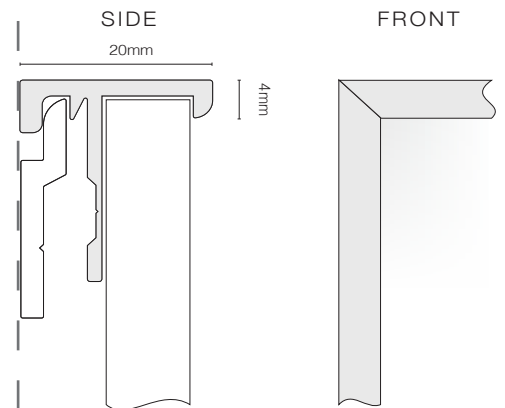

FLAT TO THE WALL MOUNTING



ACCESSORIES



Aluminum Pen Tray Included

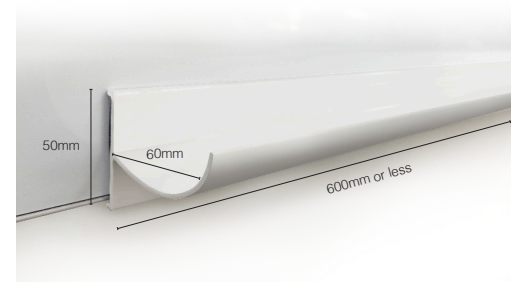

Optional White Aluminum Magnetic Pen Tray



A 31 Eastwood St, Bakery Hill VIC 3350
P (03) 5333 5977
W www.winesofficefurniture.com.au